



Libra S11 and S12 User Manual

English

Deutsch

Français

Español

Italiano

 biochrom



Biochrom Ltd
Certificate No. 890333

Declaration of Conformity

This is to certify that the Libra S11 Visible and Libra 12 UV/Visible
Spectrophotometers
Part number 80-2115-15 and 80-2115-10
Serial number 81000 onwards

manufactured by Biochrom Ltd. conform to the requirements of the following
Directives:- 73/23/EEC & 89/336/EEC

Standards to which conformity is declared

EN 61 010-1: 2001

Safety requirements for electrical equipment for measurement, control and
laboratory use.

EN 61326: 1998

Electrical equipment for measurement, control and laboratory use – EMC
requirements

Signed:

Dated: 23rd October 2002

David Parr
Managing Director
Biochrom Ltd

Postal address	Telephone	Telefax
Biochrom Ltd 22 Cambridge Science Park Milton Road Cambridge CB4 0FJ England	+44 1223 423723 e mail: enquiries@biochrom.co.uk	+44 1223 420164 website: http://www.biochrom.co.uk

Registered in England No: 3526954

Registered Office: 22 Cambridge Science Park, Milton Road, Cambridge CB4 0FJ, England.

CONTENTS

<i>Unpacking, Positioning and Installation</i>	1
<i>Essential Safety Notes</i>	2
OPERATION	3
<i>Introduction</i>	3
<i>Using the Instrument Display and Keypad</i>	4
<i>Customisation of the instrument menu</i>	5
<i>Basic Modes of Use</i>	6
<i>Enhanced Modes of Use</i>	9
<i>Method storage, recall and deletion</i>	13
SET-UP	15
<i>Menu customisation, access code and methods</i>	15
<i>Lamp settings</i>	16
<i>Display contrast and instrument output</i>	16
ERROR MESSAGES	17
OUTPUT OF RESULTS	18
<i>Use with parallel printer</i>	18
<i>Use with chart recorder</i>	18
<i>Use with PC</i>	18
ACCESSORIES	19
<i>Lamps, consumables and other items</i>	19
MAINTENANCE	20
<i>After Sales Support</i>	20
<i>Lamp Replacement</i>	20
<i>Deuterium Lamp Warranty (Libra S12)</i>	23
<i>Fuse replacement</i>	23
<i>Cleaning and general care of the instrument</i>	23
APPENDIX	24
<i>Equation entry using the Multi Wavelength mode</i>	24
SPECIFICATION	25
<i>Warranty</i>	26

Unpacking, Positioning and Installation

- Inspect the instrument for any signs of damage caused in transit. If any damage is discovered, inform your supplier immediately. Check the position of the metal lamp bracket inside the lamp access area.
- Ensure your proposed installation site conforms to the environmental conditions for safe operation:

Indoor use only

Temperature 10°C to 40°C

Maximum relative humidity of 80 % up to 31°C decreasing linearly to 50 % at 40°C

- The instrument must be placed on a hard, flat bench or table that can take its weight (6 kg) such that air is allowed to circulate freely around the instrument.
- Ensure that the cooling fan inlets and outlets are not obstructed; position at least 2 inches from the wall.
- This equipment must be connected to the power supply with the power cord supplied and **MUST BE EARTHED (GROUNDED)**. It can be used on 90 - 240V supplies.
- Switch on the instrument. Prior to calibration, the display asks you to check that the cell compartment is clear. The purpose of this is to indicate the use of the function soft keys, and how they are associated with the options presented at the bottom of the display; F2 represents OK in this instance (this display can be disabled in Set-up if required). The calibration stages are indicated in sequence (- for checking, ✓ for OK, ✕ for Fail).
- At switch on the language of the instrument can be changed if required. The relevant key below should be pressed repeatedly while the status bar is active (this is only for a couple of seconds immediately after switch on). The following numbers correspond to the languages available:

0 English 1 German 2 French 3 Spanish 4 Italian

If this equipment is used in a manner not specified or in environmental conditions not appropriate for safe operation, the protection provided by the equipment may be impaired and instrument warranty withdrawn.

Essential Safety Notes

There are a number of warning labels and symbols on your instrument. These are there to inform you where potential danger exists or particular caution is required. Before commencing installation, please take time to familiarise yourself with these symbols and their meaning.



Caution (refer to accompanying documents).
Background colour yellow, symbol and outline black.



WARNING

**UV RADIATION
HOT**



WARNING

UV RADIATION IS HARMFUL TO YOUR EYES
If power is restored with this cover removed,
eye protection must be worn

OPERATION

Introduction

Your spectrophotometer is a simple-to-use, microprocessor-controlled instrument. In addition to the basic modes of operation, the instrument has enhanced software and method storage functionality. A laboratory technician or supervisor can customise the spectrophotometer for students and operators by disabling menu options that are not required.

Your spectrophotometer:

- has basic modes of operation -
 - ◆ measurement of **absorbance**, **% transmission** and **concentration** values,
 - ◆ output of **simple kinetics assays** and **wavelength scans** to display.
- has enhanced modes of operation -
 - ◆ the facility to enter a multi point **standard curve** in memory
 - ◆ the application of a factor to an absorbance change over a specified time interval for an enzymatic determination (**reaction rate**)
 - ◆ the use of absorbance values in a **multi wavelength** equation specified by you, with direct output of results, saving post run calculation
- stores up to 9 user defined **methods**
- can have any combination of the above, including methods, enabled so as to **customise** the instrument for your own specific laboratory needs
- can be connected to a standard Centronics **parallel printer** for output of results
- can be linked via a serial interface adapter lead to a **PC** for download of results to spreadsheet, and subsequent inclusion in a laboratory information management system (LIMS)

A range of accessories further enhances the capability of the instrument.

Using the Instrument Display and Keypad



The back-lit liquid crystal display has large characters which are easily visible, useful if a group of students are gathered around for a demonstration, for example. The keypad is a spill proof membrane that is very hard wearing.

The instrument is easy to use, with function select / entry soft keys on the keypad (F1, F2 and F3) being situated directly below the corresponding option on the display; these keys are used in conjunction with on-screen prompts.

On the absorbance home page, for example, concise help text is available at the push of the F1 key, whereas Menu and Set-up are accessed by F2 and F3, respectively. On other displays, the purpose of the keys changes, but this is clearly indicated; for example, F3 acts as the “accept” option on parameter entry displays and next page (if further options exist) in the Menu and Set-up displays.

Pressing the red stop key acts as an escape mechanism in most situations.

Press:

- ← to clear incorrect user entries from the display.
- λ to enter the wavelength at which the instrument is to be used.
-  to set reference of absorbance to 0.000AU on a reference solution at the current wavelength in the mode selected. Where it is standard operating procedure, the user is prompted to insert a cell containing a reference into the cell holder.
-  to **start** making measurements or **print** results.
-  to **stop** making measurements or return to the initial parameter screen within the current operating mode.
- to print result
- Esc to stop an experiment (time intervals and wavescan only)
- OK To go to the absorbance page after calibration or from set-up.

Customisation of the instrument menu

Customisation of the menu to suit laboratory needs is an important benefit of the instrument. This facility is password protected so that only authorised personnel are able to set up or change the instrument.

- In a teaching laboratory, a laboratory technician might choose to have only the modes of Absorbance, Factor Concentration, Time Intervals and Scan available.
- In the QC lab, the supervisor may choose to have Absorbance, Standard Concentration, Multi-point Standard Curve entry and Reaction Rate.
- Similarly, a production line might have Absorbance and two methods as the instrument start up; in this case, the methods could both be multi wavelength equations involving factors, and set up in the analytical laboratory for use by operators.

To customise the instrument, refer to Set-up > Menu for further details.

Basic Modes of Use

Absorbance

Absorbance mode is default after power on and calibration. It makes simple absorbance measurements on samples, measuring the amount of light that has passed through a sample relative to a blank (this can be air). The procedure is as follows:

Press λ key and enter appropriate wavelength

Insert reference, press  key.

This reference value is used for subsequent samples until changed.

Insert samples as required and record the absorbance.

% Transmission

Transmission mode measures the amount of light that has passed through a sample relative to a blank (this can be air), but displays the result as a percentage. The procedure is as follows:

Press λ key and enter appropriate wavelength

Insert reference, press  key

This reference value is used for subsequent samples until changed.

Insert samples as required and record the transmittance.

Concentration

Factor concentration mode is used when a conversion factor is known, and is required to convert the absorbance measurement for a sample at a specific wavelength into a concentration, by a simple multiplication of absorbance x factor. The procedure is as follows:

Enter appropriate wavelength

Enter known factor (range 0.01-99999)

Insert reference, press  key

This reference value is used for subsequent samples until changed.

If you wish to save as a method, go to set-up (F3)

Insert samples as required and record the concentrations.

Time Intervals

Simple kinetics studies for teaching laboratory experiments can be readily performed. The wavelength of interest is entered together with the time interval at which absorbances are to be read; the option of having a reference reading prior to the run is available. A count down facility indicates the time remaining until the next measurement. To end an experiment, the stop key is pressed. The procedure is as follows:

Enter appropriate wavelength

Enter time unit (seconds or minutes)

Enter end time ($\leq 10,000$)

Enter the time interval for each reading (range 1-60 seconds). A minimum of 10 data points are required, and the time interval for this is calculated.

If you require a reference reading press F3 (if not, press F2)

Insert reference, press  key

This reference value is used for subsequent samples until changed.

If you wish to save as a method, go to set-up (F3)

Insert sample, press  key

Press . to print graphic

Press  key when the experiment is complete

Wavescan

An absorption spectrum can be obtained from your instrument; this enables simple identification of peak height and position. A reference scan has to be obtained first since there is no stored baseline. The procedure is as follows:

Enter start wavelength

Enter end wavelength (nearest 10, 20, 50 or 100 nm to start wavelength)

Select Absorbance or Transmission mode

Insert reference, press  key

This reference value is used for subsequent samples until changed.

If you wish to save as a method, go to set-up (F3)

Insert sample, press  key (repeat as necessary)

Press . to print graphic

Use the ◀ (F1) and ▶ (F3) keys to move the cursor in order to identify peak height and position.

To zoom in on a region, press F2 followed by the start and end wavelengths (the instrument will zoom to the nearest 10, 20, 50 or 100 nm).

Enhanced Modes of Use

Standard Concentration

Standard Concentration mode is used when a sample of known concentration is available; by measuring the absorbance of this at a specific wavelength, the conversion factor is calculated (see above), and this can be applied to other samples of unknown concentration. This is equivalent to a one point calibration, and assumes that a sample of zero concentration has zero absorbance. The procedure is as follows:

Enter appropriate wavelength

Enter concentration of known standard

Insert reference, press  key

This reference value is used for subsequent samples until changed.

Insert standard, press 

The absorbance value is displayed; press F2.

If you wish to save as a method, go to set-up (F3)

Insert samples as required and record the concentrations relative to the standard.

If recalling as a method, set reference before measuring samples.

Standard Curve

The construction of a multi point calibration curve from standards of known concentration in order to quantify unknown samples is a fundamental use of a spectrophotometer; this instrument has the advantage of being able to store this curve as a method. The procedure to construct the standard curve is as follows:

Select whether cubic spline or linear regression fit of the data points is required
Enter appropriate wavelength
Input the number of standards to be used:

For cubic spline fit, a minimum of 4 standards is required; maximum is 10.
For linear regression, a minimum of 3 data points is required (if 1 is entered, the mode reverts to standard concentration); maximum is 10.

Enter the concentrations of the standards in increasing value *.

Insert reference, press **H** key

This reference value is used for subsequent samples until changed.

Insert standard 1 of known concentration, press **D**

The absorbance is displayed; press F2 to proceed to next standard.

Repeat as necessary for all standards

Press **.** to print graphic

The display shows - - - -, signifying that the standard curve has been defined, and that samples can now be measured.

If you wish to save as a method, go to set-up (F3)

Insert samples as required and record the concentrations relative to the standard curve.

Any sample absorbance / concentration which is outside the limits defined by the standards used is displayed as - - - - .

If recalling as a method, set reference before measuring samples. The display continues to show - - - - after the set reference. To recall stored method parameters only, for example in protein assays where freshly prepared standards are frequently used with new samples, press STOP after method recall. Press enter to move through the stored method parameters, and measure the absorbances of the fresh standards in the usual way; these new values are used in the standard curve.

- To include a zero concentration standard, include this in the number of standards to be entered and enter 0.00 for concentration; use a blank when required to enter standard 1. If using duplicates, enter the same concentration twice; 2 duplicates of 3 different concentration equals 6 standards.

Reaction Rate

Reagent test kits are routinely used for the enzymatic determination of compounds in food, beverage and clinical laboratories by measuring NAD / NADH conversion at 340 nm. The change in absorbance over a specified time period can be used to provide useful information when an appropriate factor, defined in the reagent kit protocol, is applied.

Note that reaction rate and enzyme activity can be calculated if the factor used takes account of the absorbance difference per unit time, as opposed to the absorbance difference *per se*.

The correlation (quality of line fit) is calculated from 10 equally spaced absorbance / time points during the course of the experiment. The procedure is as follows:

Enter appropriate wavelength

Enter time unit (seconds or minutes)

Enter delay time, if applicable ($0 \leq 600$)

Enter end time ($\leq 10,000$)

Enter factor (range 0.01-99999)

If you require a reference reading press F3 (if not, press F2)

Insert reference, press  key

This reference value is used for subsequent samples until changed.

If you wish to save as a method, go to set-up (F3)

Insert sample, press  key.

The display indicates the change in absorbance for each of the calculated time intervals as the assay proceeds.

The result (total change in absorbance over the reaction time multiplied by the factor) is displayed; press F2 to display the correlation (a correlation of > 0.95 is expected if the assay was carried out over a linear section).

If recalling as a method, set reference before measuring samples.

Multi Wavelength Equation Entry

The measurement of Absorbance values at specific wavelengths and combining these with appropriate factors is a means of overcoming interference effects in several applications. By using the equation entry facility, post measurement calculations can be done automatically and the end result displayed for the operator. This is a very powerful facility indeed for the busy industrial, QC or environmental testing laboratory. Up to 5 wavelengths and 6 constants (5 factors relating to the absorbances at the 5 wavelengths, and a dilution factor) can be entered for one equation. The procedure is as follows (refer to Appendix for a step by step, worked through example):

Write the equation out in front of you, ensuring there are no syntax errors!

The available equation operators are:

A@1 Absorbance at wavelength 1. Enter required wavelength using keypad.

T@1 Transmission at wavelength 1. Enter required wavelength using keypad.

() + - * /

K1 Factor applied to absorbance at wavelength 1. Enter using keypad.

C1 Constant (dilution or other). Enter using keypad. Note that C1 can be applied several times, using different numerical values each occasion.

! Use if a sequence of Absorbance values only is required Enter !A@1 A@2 etc

Note that Factor and Constant can only have 5 characters, including the decimal point; thus 12.259 is not allowed, whereas 0.302 is.

The maximum length of equation that can be accommodated is 60 characters in length, where the absorbance at wavelength and factor are 3 and 5 characters, respectively, and the equation operators are 1 character.

Select Absorbance or Transmission mode

Press Next (F1) to obtain the required parameter, using the keypad for absorbance values and factors, as appropriate.

Press F2 to select the parameter and move on to the next one.

Repeat this procedure until the equation is entered.

Note that if you make an error, the ← key on the keypad will remove the last entry.

Press F3 to enter the equation once it has been input correctly.

Insert reference, press  key. A set reference at each of the required wavelengths is taken.

If you wish to save as a method, go to set-up (F3)

Insert sample, press  key.

The result of the calculations involved in the defined equation is displayed.

Press F2 to proceed to next sample

If recalling as a method, set reference before measuring samples.

Ratio

This facility enables the determination of $\text{Abs } \lambda_1 / \text{Abs } \lambda_2$ and $\text{Abs } \lambda_1 \cdot \text{factor}$

Enter the first wavelength

Enter the second wavelength

Select if background correction (for both wavelengths) is required

If yes, enter the wavelength

Enter the factor to be applied to the first wavelength

Enter dilution factor (range 1.0 – 99999)

Insert reference, press  key. A set reference at each of the required wavelengths is taken. Press F2.

If you wish to save as a method, go to set-up (F3)

Insert sample, press  key.

The results for absorbance values, concentration and the ratio are displayed. Press F2 to proceed to next sample

If recalling as a method, set reference before measuring samples.

Method storage, recall and deletion

After defining parameters in any of the above modes, and prior to measuring a sample, entry to Set-up using the F3 function key provides the opportunity to store the parameters currently loaded as a method. This option is password protected, and up to 9 methods can be saved; refer to Set-up > Methods for further details.

A stored method is enabled as an option directly on the instrument menu, so that it is possible for an operator to switch the instrument on and have a specified method available straight away; refer to Set-up > Menu for further details.

When recalling a stored method from the menu, the option to print the method parameters is presented by pressing 1; press 2 to continue with the selected method. Print the method to confirm that it is the method you require, if necessary. Once a method has been recalled, you can set reference before running samples.

If method parameters are incorrect, they cannot be changed – the method has to be erased (deleted), re-entered and then re-stored (re-saved). To remove a method, refer to Set-up > Methods.

SET-UP

After selecting the set-up option (F3) there is an initial information screen, as shown below. Press F2 (OK) to return to the absorbance home page. Press F1 to recalibrate the instrument.

Serial #	Serial Number of the instrument
6020 or 6040 V1.0	Product line number, version of EPROM
UV lamp hours	Total UV lamp life used (Libra S12)
Vis lamp hours	Total visible lamp life used
Instrument hours	Total instrument hours

To access the set-up page press F3 again. A password is required; the default is 6020 or 6040, but this can be changed.

Three displays are available:	Menu customisation, access code and methods
	Lamp settings
	Display contrast and instrument output

To go to the next display press F3.

To change or select an option press the relevant number on the keypad. Another display screen may appear depending on the option.

Use the function soft keys in conjunction with the options indicated by the display, as appropriate.

Menu customisation, access code and methods

- 1 : Menu** Press 1 to obtain a list of all the modes. These can be enabled or disabled as required by pressing the relevant number on the keypad. Disabled options are not shown on the main menu display.
- 2 : All Menu** Press 2 to show disabled options from above as greyed out text on the main menu, even though they cannot be selected.
- 3 . Access Code** Press 3 for the possibility to change the password from the default to another 4 digit number. Enter the current password (Access Code), then the new one (Access Code #1) and confirm the new one (Access Code #2). If you forget the password, contact your supplier.

- 4 : Methods** Press 4 to have the choice of either storing a new method after defining parameters or erasing an existing method. Press 1 to store the method in the next available method storage space (maximum is 9). Methods are stored in the instrument EEPROM, the process may take a few seconds. Press 2 to erase a method; the method number has to be entered. Method parameters can be printed out when the stored method is selected from the menu.

Lamp settings

- 1 : UV lamp** Switch deuterium lamp on/off (Libra S12)
- 2 : Vis lamp only** Deuterium lamp is switched permanently off; and the instrument will act as a visible only product. Infrequent users of the UV range can benefit from considerable increase in deuterium lamp life by use of this utility.
- 3 : UV lamp save** Instrument powers up and calibrates as usual, but then switches off the deuterium lamp automatically. The lamp will come on if a UV wavelength is selected (Libra S12)
- 4 : Lamp hours ⇒ 0** Resets lamp lives to zero when a new lamp is fitted.

Display contrast and instrument output

- 1 : ↑ Contrast** Increase display contrast one step at a time by pressing 1
- 2 : ↓ Contrast** Decrease display contrast one step at a time by pressing 2 (a total of seven contrast levels are available)
- 3 : Calibration Menu** Disables the “Ensure cell compartment is clear” message which appears prior to calibration.
- 4 : Output to serial** Enables output of ASCII datastream to PC via the serial interface adapter lead. The information is in tab separated format.
- 5 : Output to printer** Enables output to parallel printer via a standard Centronics cable; text only, Seiko DPU-414, HP DeskJet (A4), HP DeskJet (letter).

ERROR MESSAGES

The following are a selection of error messages that are available:

<i>Reset to defaults</i>	Memory was corrupted in some way and re-set to defaults. Display options and methods need to be re-entered.
<i>UV lamp fail</i>	UV lamp failed to strike. May need replacing – check lamp hours (Libra S12)
<i>Vis lamp fail</i>	Visible lamp failed to strike. May need replacing – check lamp hours
<i>Beam blocked</i>	Something is in the way of the beam – check sample compartment area
<i>Wavelength error</i>	A calibration failure or corruption has caused the instrument to go an invalid wavelength. May need service engineer.
<i>Lamps overheating</i>	The thermal sensor on the lamp cover has detected a temperature in excess of its limits – call service engineer.
<i>PSU overheating</i>	PSU thermistor is indicating a temperature in excess of 70°C – call service engineer.

OUTPUT OF RESULTS

Use with parallel printer

Any Centronics parallel printer can be used together with the appropriate cable. If using a thermal printer, ensure it is set up to print out for a page width of 80 characters. Ensure output to printer is on in the Set-up.

Output is automatic when the  key is pressed, and a printer is connected and switched on. Umlauts and accents are not printed out with letters if the instrument is set up to be in German, French, Italian or Spanish.

Appropriate headers and relevant information are printed out for enhanced modes, for example the absorbance – concentration values of the standards in standard curve mode, and the equation (with values) entered in Multi Wavelength mode.

Use with chart recorder

The chart recorder interface lead, 80-2109-03, is required; time intervals and scan modes only will output to a chart recorder in a meaningful way. The output is via pin 24 (+) and pin 25 (-) of the 25 pin D connector if you wish to make your own. Output is non-synchronised, that is the chart recorder must be switched to run independently. The output is 100 mV for 1.000 abs unit, and a suggested chart speed is 10 mm / second. Note that an offset is required; - 0.5 Abs = 0 mV, 0.0 Abs = 50 mV, 3.0 Abs = 350 mV (use Absorbance mode to set these pen positions on the chart recorder).

Use with PC

NOTE: A standard serial interface will not work.

1) Download to Spreadsheet

The serial interface adapter lead (80-2109-02) is required; it is also supplied with Spreadsheet Interface Software for direct download to Excel. This macro is supplied on a floppy disc together with instructions for installation and use.

2) Use with Hyperterminal

The serial interface adapter lead (80-2109-02) is required; ensure output to serial is on in Set-up. The ASCII stream is output at 19,200 Baud via the 25 way D connector on the rear panel, and can be picked up by a PC with Windows installed. Use the Hyperterminal emulator in Accessories to pick this up (settings are Handshake None, 19,200 Baud, 1 stop bit, 8 data bits, 0 parity, Comm port depends on which port the lead is connected to). Output is automatic if the interface lead is connected to the instrument.

ACCESSORIES

Each accessory is supplied integrated into its own sample compartment for ease of fitting and cleaning.

Easy to fit - when changing accessory / sample compartment, snap the old one out and the new one in.

Easy to clean - take the whole assembly out and run it under the tap.

Acquire Lite applications software	80-2112-24
Manual 2 position 10mm cell changer	80-2109-04
10 – 50mm cell holder	80-2109-05
Water heated cell holder (requires circulating bath)	80-2109-06
Electrically heated cell holder (requires Temperature Controller)	80-2109-07
Temperature Controller (25, 30, 37°C)	80-2112-54
Fitting kit for external sample delivery (requires peristaltic pump and 10mm pathlength flowcell)	80-2109-08
Test tube holder and cover (accommodates diameters of 8-26 mm and heights of up to 180 mm)	80-2109-33
Spare 10mm single cell holder	80-2109-09
Cylindrical cell holder (50mm pathlength cylindrical cells)	80-2112-26

Lamps, consumables and other items

Tungsten halogen lamp (Libra S12)	80-2106-16
Tungsten halogen lamp (Libra S11)	80-2022-94
Deuterium lamp (Libra S12)	80-2109-11
Serial Interface Adapter Lead (includes Spreadsheet Interface Software)	80-2109-02
Chart Recorder Lead	80-2109-03
Centronics parallel printer lead	80-2071-87
Dust cover	80-2109-13

Contact your supplier for details on our range of disposable, UV silica and glass cells.

MAINTENANCE

After Sales Support

We supply support agreements that help you to fulfil the demands of regulatory guidelines concerning GLP/GMP.

- ◆ Calibration, certification using filters traceable to international standards
- ◆ Certificated engineers and calibrated test equipment
- ◆ Approved to ISO 9001 standard

Choice of agreement apart from break down coverage can include

- ◆ Preventative maintenance
- ◆ Certification

When using calibration standard filters, insert such that the flat surface is facing away from the spring end of the cell holder

Observe all necessary precautions if dealing with hazardous samples or solvents.

Lamp Replacement

Replacement lamps are available from your supplier using the following part numbers:

Deuterium Lamp	80-2109-11 (Libra S12)
Tungsten Lamp	80-2106-16 (Libra S12), 80-2022-94 (Libra S11)



(use only this tungsten lamp; others will not operate correctly in a spectrophotometer)

The design of the lamp area is such that users are able to change their own lamps. No lamp alignment is necessary as the lamps are pre-aligned at manufacture.

The lamps become very hot in use. Ensure they cool before changing them.

Do not touch the optical surfaces of either lamp with your fingers (use tissue); if touched, the area should be cleaned with iso-propanol.

To replace a lamp proceed as follows:

- 1) Switch off the instrument, remove the sample from the cell holder and disconnect the power supply cord.
- 2) Locate the lamp access cover at the back of the instrument, unscrew the cover and remove.
- 3) Move the metal bracket sideways, slide the lamp plate assembly out and unplug the connector.
 - if the tungsten lamp has failed, the replacement should be inserted onto the plate, pushing it all the way down into its holder.
 - if the deuterium lamp has failed, insert the old tungsten lamp onto the plate as above and then replace the whole assembly with the new one.
- 4) Reconnect the cable connector and slide the lamp plate in until it locates, checking that the cable or connector does not interfere with the relocation.
- 5) If you have difficulty in sliding the lamp assembly back into position hold the connector down and push the lamp plate until it locates correctly.
- 6) Replace the lamp access cover.
- 7) Reconnect the power supply cord and switch the instrument on.
- 8) Reset the lamp life to zero by:
 - F3 Set-up → F3 Set-up → enter password → F3, F3 → select 4 → F3 (✓), → select which lamp life is to be changed to zero.
 - Exit this screen by pressing the  key
 - Exit set-up by pressing the  key.

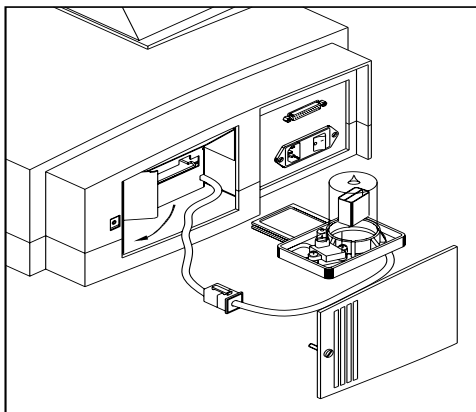

Lamp Replacement Libra S11 Only – proceed as follows

Tungsten Lamp



80-2022-94 (Libra S11)

(use only this tungsten lamp; others will not operate correctly in a this spectrophotometer)

To replace a lamp proceed as follows:

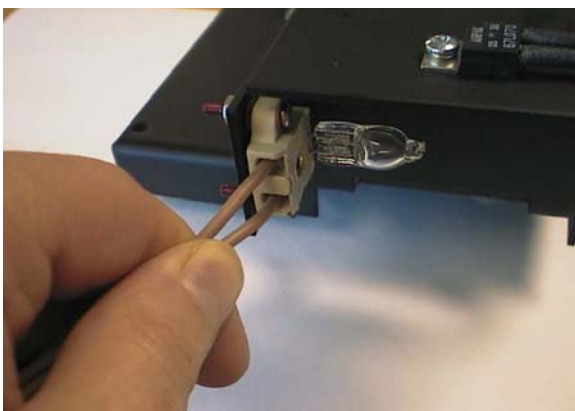
- 1) Switch off the instrument, remove the sample from the cell holder and disconnect the power supply cord.
- 2) Locate the lamp access cover at the back of the instrument, unscrew the cover and remove.
- 3) Using a lens cloth, grip the lamp and pull it out. This is achieved more easily by gently pulling on the two brown wires at the same time, to release the springs holding the lamp in place.



- 4) The replacement tungsten lamp should be inserted onto the plate, pushing it all the way down into its holder. Use a lens cloth to hold the new lamp. Again the brown wires can be gripped and pulled towards you to ease this process. Ensure the lamp is located as far inside the holder as possible. It should also appear horizontally positioned.
- 5) Replace the lamp access cover.
- 6) Reconnect the power supply cord and switch the instrument on.
- 7) Reset the lamp life to zero by:
F3 Set-up → F3 Set-up → enter password → F3, F3 → select 4 → F3 (✓),
→ select which
lamp life is to be changed to zero.
Exit this screen by pressing the  key
Exit set-up by pressing the  key.

Deuterium Lamp Warranty (Libra S12)

Criteria for lamp replacement are that it must:

- be less than 15 months old AND
- have had less than 750 hours use

Fuse replacement

Switch off the instrument and disconnect the power supply cord. The fuse holder can only be opened if the power supply plug has been removed, and is located between the power input socket and the on/off switch on the back panel of the instrument.

Slide open the fuse holder by pulling at the notch.

Place fuses (2A, 5mm x 20mm, FST) into the fuse holder and slide back into position.

Reconnect the power supply cord and switch on the instrument.

Fuses are not normally consumed in an instrument's lifetime. If they blow repeatedly, contact your supplier.

Cleaning and general care of the instrument

External cleaning

Switch off the instrument and disconnect the power cord.

Use a soft damp cloth.

Clean all external surfaces.

A mild liquid detergent may be used to remove stubborn marks.

Sample compartment spillage

Switch off the instrument and disconnect the power cord.

Remove the cell holder by snapping it out.

Clean it separately with a soft damp cloth, or hold it under running water from a tap.

APPENDIX

Equation entry using the Multi Wavelength mode

Always write out the equation in front of you before using this mode.

Step by step entry of the following equation is shown in the example below:

$$\text{Cobalt (g/l)} = ((A511 * 12.26) - (A720 * 0.302)) * 100$$

Note that if you make an error, the ← key on the keypad will remove the last entry.

Press Next (F1) until (appears. Press select (F2).

Press Next (F1) until (appears. Press select (F2).

Press Next (F1) until A@1 appears. Press select (F2).

Press 511 on the keypad. Press enter (F3).

Press Next (F1) until * appears. Press select (F2).

Press Next (F1) until K1 appears. Press select (F2).

Press 12.26 on the keypad. Press enter (F3).

Press Next (F1) until) appears. Press select (F2).

Press Next (F1) until – appears. Press select (F2).

Press Next (F1) until (appears. Press select (F2).

Press Next (F1) until A@2 appears. Press select (F2).

Press 720 on the keypad. Press enter (F3).

Press Next (F1) until * appears. Press select (F2).

Press Next (F1) until K2 appears. Press select (F2).

Press 0.302 on the keypad. Press enter (F3).

Press Next (F1) until) appears. Press select (F2).

Press Next (F1) until) appears. Press select (F2).

Press Next (F1) until * appears. Press select (F2).

Press Next (F1) until C1 appears. Press select (F2).

Press 100 on the keypad. Press enter (F3).

Check the equation on the display.

Press F3 to accept the equation

To save the equation as a method, refer to Set-up.

SPECIFICATION

<i>Wavelength range</i>	325- 999 nm (Libra S11) or 200 – 999 nm (Libra S12)
<i>Monochromator</i>	Plane grating with 1200 lines/mm
<i>Wavelength calibration</i>	automatic upon switch on
<i>Spectral bandwidth</i>	5 nm
<i>Wavelength accuracy</i>	± 2nm
<i>Wavelength reproducibility</i>	± 0.5nm
<i>Light sources</i>	tungsten halogen and deuterium arc (Libra S12)
<i>Detector</i>	single solid state silicon photodiode
<i>Photometric range</i>	- 0.300 to 3.000A, 0.01 to 99999 concentration units, 0.1 to 200%T
<i>Photometric linearity</i>	±0.5% or ± 0.005A to 2.000A at 546nm, whichever is the greater
<i>Photometric reproducibility</i>	0.5% of absorbance value to 2.000A at 546nm
<i>Stray Light</i>	typically <0.2%T at 220nm using NaI, <0.2%T at 340nm using NaNO ₂ according to ANSI/ASTM E387- 72
<i>Stability</i>	± 0.002A/h at 0A and 546nm after warm-up, typically 30 minutes
<i>Noise</i>	± 0.001A near 0A and ± 0.002A near 2A at 600nm
<i>Scan speed</i>	250 nm/minute
<i>Analogue output</i>	100mV per 1.000A via interface lead
<i>Digital output</i>	Centronics parallel as standard 9 pin serial via interface adapter lead
<i>Dimensions</i>	310 x 400 x 180 mm
<i>Weight</i>	6 kg
<i>Power requirements</i>	90-265 V, 50/60 Hz, 100 VA
<i>Safety standard</i>	EN61010-1
<i>EMC emissions</i>	EN 61326-2.3 Generic emissions
<i>EMC immunity</i>	EN 61000-4-6 Generic immunity part 1
<i>Mains harmonics</i>	EN 61000-3-2
<i>Susceptibility standard</i>	IEC 801
<i>Quality System</i>	Designed and manufactured in accordance with an ISO 9001 approved quality system

Specifications are measured after the instrument has warmed up at a constant ambient temperature and are typical of a production unit. As part of our policy of continuous development, we reserve the right to alter specifications without notice.

Warranty

Your supplier guarantees that the product supplied has been thoroughly tested to ensure that it meets its published specification. The warranty included in the conditions of supply is valid for 12 months only if the product has been used according to the instructions supplied. They can accept no liability for loss or damage, however caused, arising from the faulty or incorrect use of this product.

This product has been designed and manufactured by Biochrom Ltd, 22 Cambridge Science Park, Milton Road, Cambridge CB4 0FJ, UK.